

Instruction Manual

Model 510-060 / 510-061

Manual Operated Cylinder Vise Station

The Cylinder Vise Station is Designed to Efficiently and Safely Retain Industrial Compressed Gas Cylinders During the Valving and De-Valving Process

If the Vise with Stand, #510-060 was purchased:

After unpacking, carefully check the unit over for shipping damage. Report any damage found with the delivering freight carrier immediately.

Once you have decided on the placement of your vise, the frame should be bolted to the floor with a minimum of four 3/8" diameter bolts. The vise ratchet and belt assembly should now be bolted to the frame with the supplied 4 bolts and nuts.

The vise is now ready to use.

If the Vise Only, #510-061 was purchased:

After unpacking, carefully check the unit over for shipping damage. Report any damage found with the delivering freight carrier immediately.

Once you have decided on the placement of your vise, it should be bolted to the work bench with a minimum of four 3/8" diameter bolts. The vise is now ready to use.

Continue...



Hydro-Test Products LLC.

85 Hudson Road Stow, Massachusetts, USA 01775

Tel: 800-225-9488 / 978-897-4647 Fax: 978-897-1942

www.hydro-test.com

Main Components of Vise Station

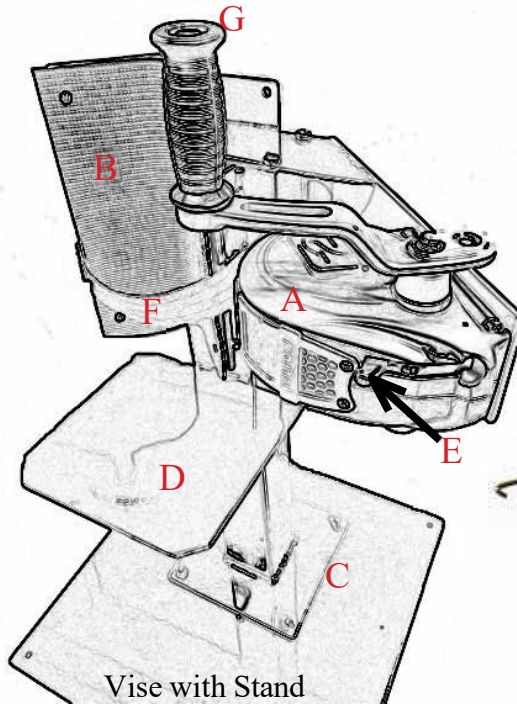

Key	Part No.	Description
A	230-052	Manual Winch Assembly with strap
B	130-020	Back Pad
C	510-062	Steel Stand with Shelf Plate
D	<i>Available Upon Request</i>	Shelf Plate
E	<i>Available Upon Request</i>	Winch Clutch lever
F	230-053	Strap
G	230-054	Replacement Winch Handle
H	230-056	Spring Clip for Clutch Lever

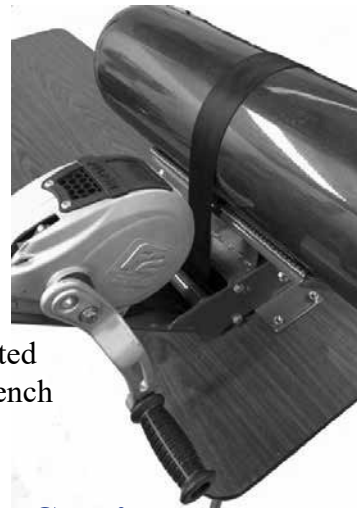

Vise Mounted
on Work Bench

Operating The Vise Station

- Place cylinder in vise, using shelf plate for portable size cylinders.
- De-activate the winch clutch by pushing clutch lever towards steel frame, turn handle until enough strap is available to go around cylinder.
- Grasp the clasp at the free end of the strap and connect to eyebolt on opposite end of steel angle frame.
- Activate the winch clutch by pushing clutch lever away from steel frame, turn handle until strap is tight around cylinder.
- You can now start de-valving or valving your cylinder. Use the cylinder manufacturers recommended torque specifications or the applicable Compressed Gas Association pamphlets.
- For “full size” cylinders, simply remove the shelf plate prior to positioning cylinder in the vise.
- If using the vise on a work bench, it is advisable to use only on portable size cylinders to avoid possible injury in attempting to lift full size cylinders to horizontal position.

Hydro-Test Products LLC.

85 Hudson Road Stow, Massachusetts, USA 01775

Tel: 800-225-9488 / 978-897-4647 Fax: 978-897-1942

www.hydro-test.com

HYDRO-TEST PRODUCTS, LLC TERMS AND CONDITIONS:

DEFINITIONS: As stated herein:

The term "Seller" or "Manufacturer" shall mean Hydro-Test Products, LLC., the warranting party.

The term "Buyer" shall mean the person(s) or entity that purchases the product from the Seller.

The term "timely inspection" shall mean the Buyer(s) inspection five (5) day period to inspect the product upon receipt of the product and report any product damage(s) as described in the WARRANTY section to the freight carrier that delivered the product.

The term "product(s)" shall mean any and all products, parts, equipment, major equipment, or any other purchase made from Hydro-Test Products, LLC.

PRICES: ALL PRICES LISTED ARE IN U.S. DOLLARS. ANY PRICES LISTED ARE SUBJECT TO CHANGE WITHOUT NOTICE.

MINIMUM BILLING: MINIMUM BILLING IS \$25.00, exclusive of freight charges.

TERMS: • NET 30 DAYS TO PRE-ESTABLISHED ACCOUNTS • DISCOUNTS ARE OFFERED FOR PRE-PAYMENT • MASTER CARD - VISA AND AMERICAN EXPRESS ARE ACCEPTED. SELECTION AND USE OF CREDIT CARD FOR PAYMENT WILL INCUR AN ADDITIONAL 3% PROCESSING FEE.

EXPORT TERMS: PAYMENT IN U.S. DOLLARS WITH CHECK OR DIRECT TRANSFER. C.I.F. PROFORMA QUOTATIONS UPON REQUEST.

SHIPPING: ALL SALES ARE F.O.B. STOW, MA., AND BECOME PROPERTY OF THE BUYER UPON SHIPMENT. ALL SHIPMENTS ARE MADE BY THE MOST ECONOMICAL MEANS AS DETERMINED BY HYDRO-TEST PRODUCTS, LLC. PREMIUM FREIGHT (UPS AIR, FEDERAL EXPRESS, ETC...) SERVICE IS MADE AVAILABLE TO ESTABLISHED ACCOUNTS; OTHERWISE, CARRIER ACCOUNT NUMBER MUST BE SUPPLIED FOR FREIGHT BILLING.

OTHER CHARGES: APPLICABLE TAXES (MA.), SPECIAL PACKAGING, EXPORT DOCUMENTATION, PREMIUM FREIGHT OR OTHER UNIQUE CHARGES ARE PAYABLE BY THE BUYER.

RETURNS: CONTACT HYDRO-TEST PRODUCTS, LLC PRIOR TO MAKING ANY RETURNS FOR R.A. #, AND INSTRUCTIONS. UNLESS OTHERWISE STATED IN THE QUOTATION, A MINIMUM RESTOCKING CHARGE OF 15% APPLIES TO ALL SALEABLE GOODS ACCEPTED AS AN ACCOMMODATION TO THE BUYER. UNAUTHORIZED RETURNS WILL NOT BE ACCEPTED. RETURNS ARE TO BE MADE TO:

HYDRO-TEST PRODUCTS, LLC., 85 HUDSON ROAD, STOW, MA. 01775.

LIMITED WARRANTY: HYDRO-TEST PRODUCTS, LLC WARRANTS THAT ALL MERCHANDISE IS FREE FROM DEFECTS IN MATERIAL AND WORKMANSHIP WHEN SHIPPED FOR A PERIOD OF TWELVE (12) MONTHS ON MAJOR EQUIPMENT, AND THIRTY (30) DAYS ON CONSUMABLE REPLACEMENT COMPONENTS (I.E. VALVES, SEALS, HOSES, QUICK COUPLERS, ADAPTERS, ETC...), AND THOSE COMPONENTS ON MAJOR EQUIPMENT UNDER NORMAL USAGE. FOR EQUIPMENT OR ITEMS NOT MANUFACTURED BY HYDRO-TEST PRODUCTS, LLC., THE ORIGINAL MANUFACTURERS WARRANTY SHALL BE IN EFFECT.

IT IS THE RESPONSIBILITY OF THE BUYER TO INSPECT THE PRODUCT WITHIN FIVE (5) DAYS OF RECEIPT OF THE PRODUCT, THIS INCLUDES ANY HIDDEN DAMAGE TO THE PRODUCT, AND THE BUYER UPON TIMELY INSPECTION SHALL REPORT KNOWN DAMAGE TO THE FREIGHT CARRIER. ALL WARRANTY WORK IS ON A FOB ("FREE ON BOARD") STOW, MASSACHUSETTS. BASIS AND EXCLUDES ANY / ALL FREIGHT SHIPPING COSTS. THERE ARE NO ADDITIONAL IMPLIED WARRANTIES AND IN NO EVENT WILL HYDRO-TEST PRODUCTS, LLC. BE LIABLE FOR INCIDENTAL OR COINCIDENTAL DAMAGES.

Hydro-Test Products LLC.

85 Hudson Road Stow, Massachusetts, USA 01775

Tel: 800-225-9488 / 978-897-4647 Fax: 978-897-1942

www.hydro-test.com

VOID WARRANTY: ALL WARRANTIES ARE VOID IF DUE TO SELLER MISUSE, OR WITH ANY ALTERATION, OR ACCIDENTAL DAMAGES TO THE MANUFACTURER'S PRODUCT(S).

CHOICE OF LAW: All legal disputes shall be resolved through binding arbitration in accordance with the laws of the State of Massachusetts, U.S.A.

DISCLAIMER: Seller is not responsible for ensuring Buyer is up to date and attending required regulatory training or safety training for use of proper use of the equipment or the products sold to Buyer. Buyer is solely responsible for scheduling Buyer's own training and ensuring that Buyer is competent with the current laws and regulations of the product(s) or equipment purchased and competent on use of the equipment and/or product(s) and competent to recognize the need for additional parts or products for updating purchased product(s) and equipment to meet ongoing updated federal and state regulations.

INDEMNITY AND HOLD HARMLESS:

BUYER HEREBY AGREES TO INDEMNIFY, HOLD HARMLESS, AND DEFEND HYDRO-TEST PRODUCTS, LLC., ITS EMPLOYEES, HEIRS, ASSIGNS, AND ANY RELATED COMPANY IN PRIVITY WITH HYDRO-TEST PRODUCTS, LLC, FOR THE BUYER'S MISUSE OF THE EQUIPMENT; FAILURE TO UNDERSTAND, ACKNOWLEDGE, AND IMPLEMENT THE CURRENT FEDERAL REGULATIONS FOR ANY AND ALL PRODUCTS PURCHASED FROM HYDRO-TEST PRODUCTS LLC, INCLUDING DISTRIBUTION OF THE SAME; FAILURE TO ATTEND AND SCHEDULE REQUIRED FEDERAL DEPARTMENT OF TRANSPORTATION HAZMAT TRAINING AND REGULATORY INSTRUCTION OF ANY AND ALL PRODUCTS PURCHASED FROM HYDRO-TEST PRODUCTS, LLC; OR TO COMPLY WITH ANY OTHER FEDERAL REGULATORY DEPARTMENT. BUYER AGREES THAT IN NO EVENT SHALL HYDRO-TEST PRODUCTS, LLC BE LIABLE FOR PUNITIVE, SPECIAL, DIRECT, INDIRECT, INCIDENTAL, ACTUAL, OR CONSEQUENTIAL DAMAGES OF ANY KIND, INCLUDING BUT NOT LIMITED TO LOSS OF USE, LOSS OF PROFIT OR REVENUE, LOSS OF GOOD WILL, OR OTHER COMMERCIAL LOSS INJURY WHETHER OR NOT HYDRO-TEST PRODUCTS, LLC HAS BEEN ADVISED OR OTHERWISE PUT ON NOTICE OF THE POTENTIAL FOR SUCH DAMAGES. HYDRO-TEST PRODUCTS, LLC SHALL NOT BE LIABLE FOR BUYER MISUSE, OR BUYER OR USER ALTERATIONS OF THE PRODUCTS; OR LACK OF EDUCATION TO PROPERLY AND SAFELY USE EQUIPMENT IN ACCORDANCE WITH THE EQUIPMENT HANDBOOK AND FEDERAL AND STATE REGULATORY REQUIREMENTS. MOREOVER, SELLER SHALL NOT BE RESPONSIBLE FOR THE BUYER'S FAILURE TO RECOGNIZE THE NEED FOR ADDITIONAL EQUIPMENT TO KEEP THE MAJOR EQUIPMENT AND MACHINES UP TO CURRENT REGULATORY CODE AND TO COMPLY WITH UPDATED AND NEW REGULATORY RULES AND REGULATIONS FOR ANY AND ALL TESTING REQUIREMENTS OR GUIDELINES. BUYER ACKNOWLEDGES THAT THE BUYER IS SOLEY RESPONSIBLE AND SOLEY LIABLE FOR ITS SAFE AND PROPER LEGAL USE OF THE EQUIPMENT IT PURCHASES FROM SELLER. FURTHER, BUYER HEREBY AGREES TO INDEMNIFY AND HOLD HARMLESS, AND DEFEND HYDRO-TEST PRODUCTS, LLC FOR ANY LOSS OR INJURIES CAUSED BY THE INSTALLATION OR USE OF PRODUCTS.

ARBITRATION: BY BUYING EQUIPMENT FROM HYDRO-TEST PRODUCTS, LLC. THE BUYER ACCEPTS THE TERMS AND AGREES TO BINDING ARBITRATION SUBJECT TO AND IN ACCORDANCE MASSACHUSETTS LAW, U.S.A, UNLESS BUYER OBJECTS TO ARBITRATION IN WRITING TO SELLER WITHIN 10 DAYS OF A PURCHASE FROM BUYER.

THIS AGREEMENT SHALL APPLY TO ANY AND ALL PRODUCTS PURCHASED FROM HYDRO-TEST PRODUCTS, LLC AND THIS AGREEMENT SHALL BE IN FULL EFFECT UPON THE PURCHASE OF ANY AND ALL PRODUCTS PURCHASED FROM HYDRO-TEST PRODUCTS, LLC.

Hydro-Test Products LLC.

85 Hudson Road Stow, Massachusetts, USA 01775

Tel: 800-225-9488 / 978-897-4647 Fax: 978-897-1942

www.hydro-test.com